

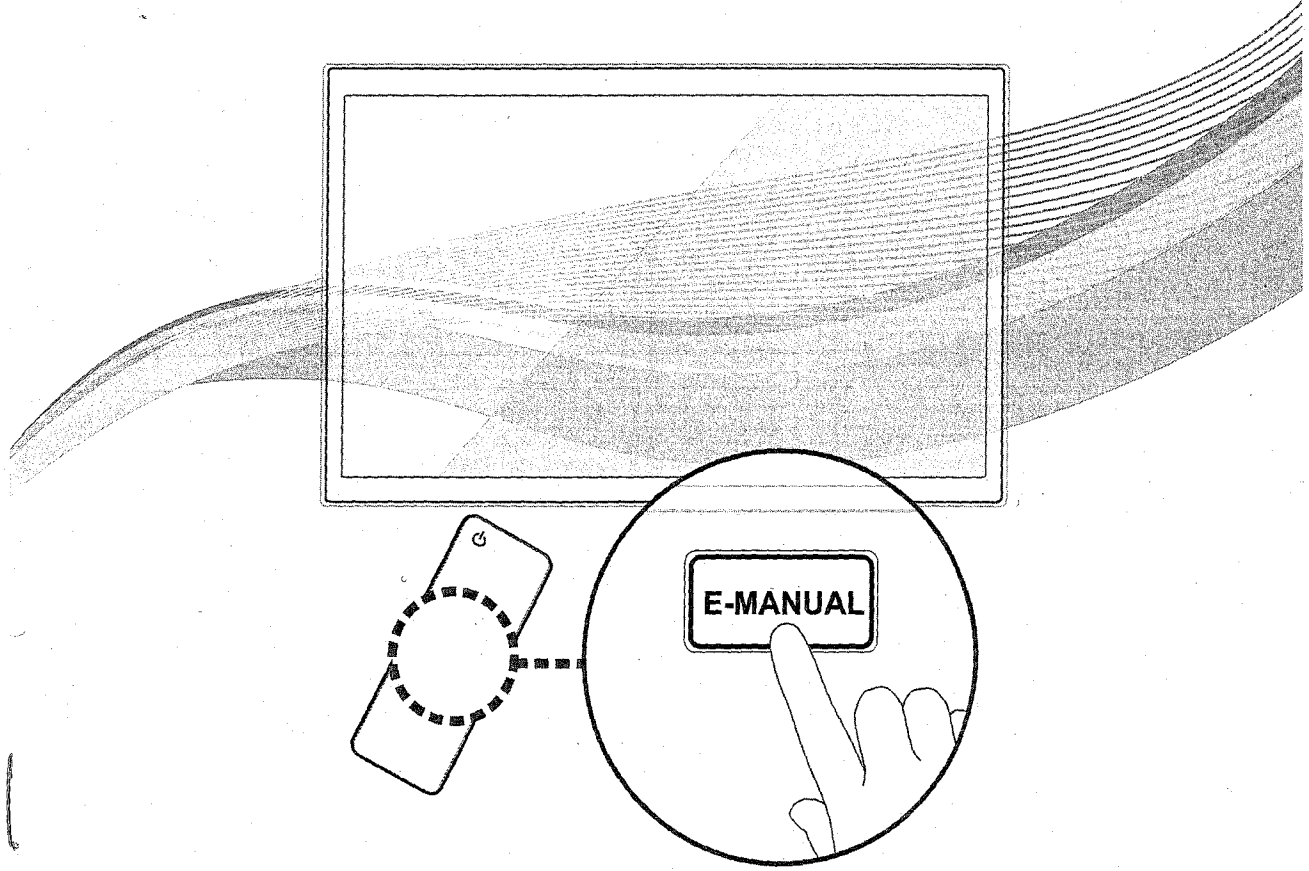

SERIES **4**
4000
4010

LED TV

User Manual



imagine the possibilities

Thank you for purchasing this Samsung product.
To receive more complete service, please register
your product at
www.samsung.com/register

Model _____ Serial No. _____

If you have any questions, please call us at 1-800-SAMSUNG (1-800-726-7864) for assistance.

For more information about how to use e-Manual (P. 13)

Figures and illustrations in this User Manual are provided for reference only and may differ from actual product appearance. Product design and specifications may be changed without notice.

Important Warranty Information Regarding Television Format Viewing

See the warranty card for more information on warranty terms.

Wide screen format LED Displays (16:9, the aspect ratio of the screen width to height) are primarily designed to view wide screen format full-motion video. The images displayed on them should primarily be in the wide screen 16:9 ratio format, or expanded to fill the screen if your model offers this feature and the images are constantly moving. Displaying stationary graphics and images on screen, such as the dark sidebars on non-expanded standard format television video and programming, should be limited to no more than 5% of the total television viewing per week.

Additionally, viewing other stationary images and text such as stock market reports, video game displays, station logos, web sites or computer graphics and patterns, should be limited as described above for all televisions. Displaying stationary images that exceed the above guidelines can cause uneven aging of LED Displays that leave subtle, but permanent burned-in ghost images in the LED picture. To avoid this, vary the programming and images, and primarily display full screen moving images, not stationary patterns or dark bars. On LED models that offer picture sizing features, use these controls to view different formats as a full screen picture.

Be careful in the selection and duration of television formats you use for viewing. Uneven LED aging as a result of format selection and use, as well as burned-in images, are not covered by your Samsung limited warranty.

• SAMSUNG ELECTRONICS NORTH AMERICAN LIMITED WARRANTY STATEMENT

Subject to the requirements, conditions, exclusions and limitations of the original Limited Warranty supplied with Samsung Electronics (SAMSUNG) products, and the requirements, conditions, exclusions and limitations contained herein, SAMSUNG will additionally provide Warranty Repair Service in the United States on SAMSUNG products purchased in Canada, and in Canada on SAMSUNG products purchased in the United States, for the warranty period originally specified, and to the Original Purchaser only.

The above described warranty repairs must be performed by a SAMSUNG Authorized Service Center. Along with this Statement, the Original Limited Warranty Statement and a dated Bill of Sale as Proof of Purchase must be presented to the Service Center. Transportation to and from the Service Center is the responsibility of the purchaser. Conditions covered are limited only to manufacturing defects in material or workmanship, and only those encountered in normal use of the product.

Excluded, but not limited to, are any originally specified provisions for, in-home or on-site services, minimum or maximum repair times, exchanges or replacements, accessories, options, upgrades, or consumables.

For the location of a SAMSUNG Authorized Service Center, please call toll-free:

- In the United States: 1-800-SAMSUNG (1-800-726-7864)
- In Canada: 1-800-SAMSUNG

Still image warning

Avoid displaying still images (such as jpeg picture files), still image elements (such as TV channel logos, stock or news bars at the screen bottom etc.), or programs in panorama or 4:3 image format on the screen. Constantly displaying still pictures can cause image burn-in on the LED screen, which will affect image quality. To reduce risk of this effect, please follow the recommendations below:

- Avoid displaying the same TV channel for long periods.
- Always try to display any image in full screen. Use the TV set's picture format menu for the best possible match.
- Reduce brightness and contrast values to the minimum required to achieve the desired picture quality. Exceeding the minimum required values may speed up the burn-in process.
- Frequently use all TV features designed to reduce image retention and screen burn-in. Refer to appropriate e-Manual sections for details.

Securing the Installation Space

Keep the required distances between the TV, the wall, and other objects to ensure proper ventilation. Failing to do so may result in a fire or a problem with the TV caused by an increase in its internal temperature.

When using a stand or wall-mount, use parts provided by Samsung Electronics only.

- If you use parts provided by another manufacturer, it may result in a problem with the product or an injury due to the product falling.

Installation with a stand.

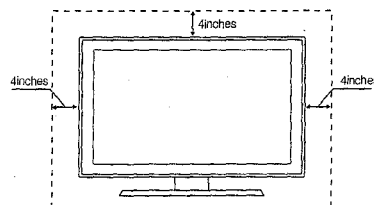

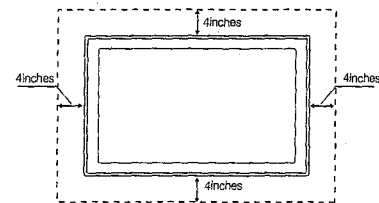

Installation with a wall-mount.



Other Warnings

- The actual appearance of the TV may differ from the images in this manual, depending on the model.
- Be careful when you touch the TV. Some parts can be somewhat hot.

Accessories

-  Please make sure the following items are included with your TV. If any items are missing, contact your dealer.
-  The item's colors and shapes may vary depending on the models.

- Remote Control (AA59-00463A) & Batteries (AAA x 2)
- Power Cord
- Owner's Instructions
- Warranty Card / Safety Guide



Component Adapter



Holder-Wire stand



Holder-Ring (4EA)

Input Cables (Sold Separately)

To purchase RS232 cable, contact www.SamsungParts.com.



RS232 (AA39-00311A)



HDMI



HDMI-DVI

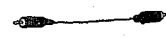

Audio

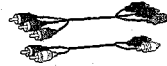

Component

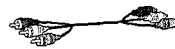

Video (AV)

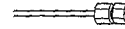





Coaxial (RF)

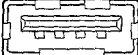

VGA

-  Check the cable before plug-in

	Cable	Ports
HDMI		
USB		
Optical		









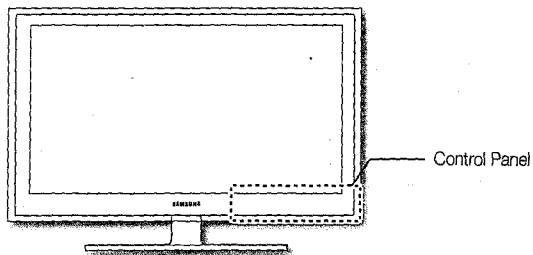



Do not plug cable upside down.
Be sure to check before plug-in.

Viewing the Control Panel

 The product color and shape may vary depending on the model.



Remote control sensor	Aim the remote control towards this spot on the TV.
Power Indicator	Blinks and turns off when the power is on and lights up in standby mode.
SOURCE 	Toggles between all the available input sources. In the on-screen menu, use this button as you would use the ENTER  button on the remote control.
MENU 	Displays an on-screen menu, the OSD (on screen display) of your TV's features.
-VOL+ 	Adjusts the volume. In the OSD, use the -VOL+ buttons as you would use the  and  buttons on the remote control.
▼ CH ▲ 	Changes the channels. In the OSD, use the ▼ CH ▲ buttons as you would use the  and  buttons on the remote control.
 (Power)	Turns the TV on or off.

Standby mode

Your TV enters Standby mode when you turn it off and continues to consume a small amount of electric power. To be safe and to decrease power consumption, do not leave your TV in standby mode for long periods of time (when you are away on a holiday, for example). It is best to unplug the power cord.

Installing the TV Stand

Components

When installing the stand, use the provided components and parts.

(A) 1 EA

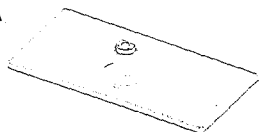

(B) 1 EA



(C)  x4 (M4 X L12)

(D)  x4 (M4 X L8)

Stand (depending on the model)

Guide Stand

Screws

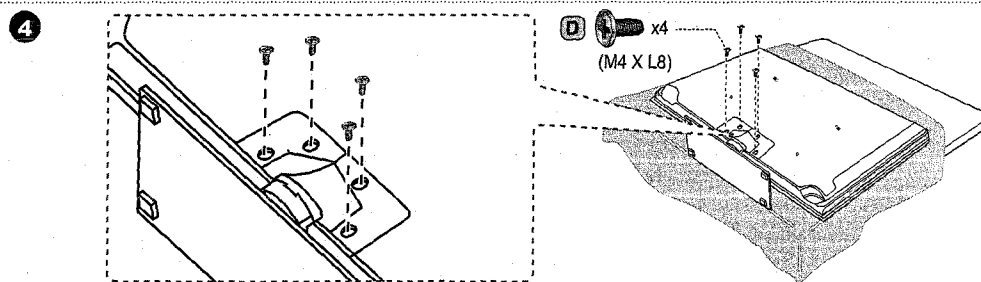
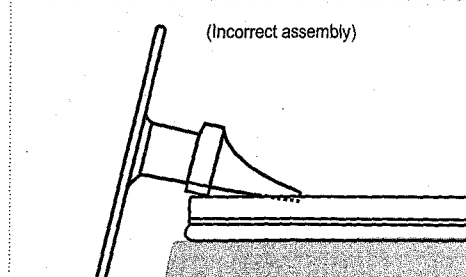
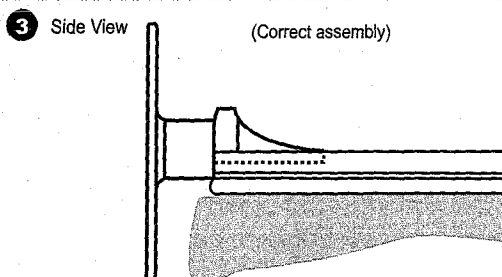
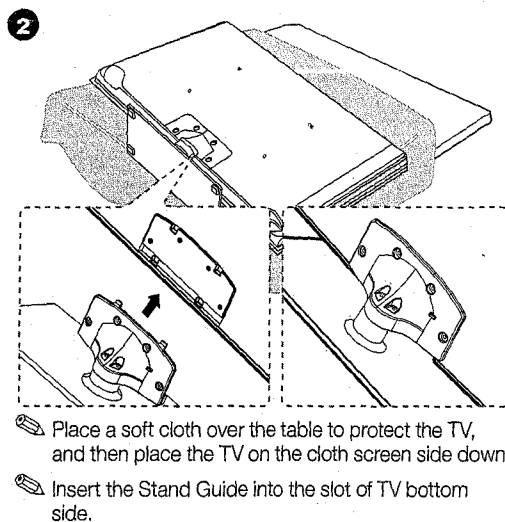
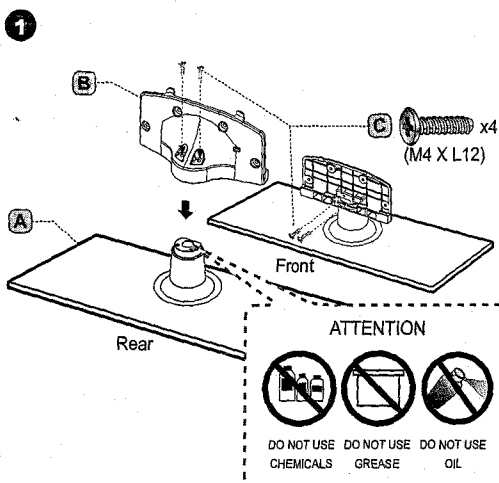

Caution  > Make sure to distinguish between the front and back of each component when assembling them.
 > Make sure that at least two persons lift and move the TV.

Installing the Wall Mount



Wall or Ceiling Mounting

The product should be mounted to a wall or ceiling only as recommended by the manufacturer. Unless it is correctly mounted, the product may slide or fall, causing serious injury to a child or adult, and serious damage to the product.

Preparing before installing Wall-Mount

To install a wall-mount from another manufacturer, use the Holder-Ring.

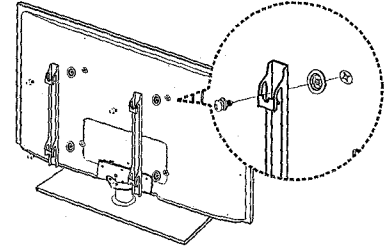

Installing the Wall Mount Kit

The wall mount kit (sold separately) allows you to mount the TV on the wall.

For detailed information on installing the wall mount, see the instructions provided with the wall mount items. Contact a technician for assistance when installing the wall mount bracket. Samsung Electronics is not responsible for any damage to the product or injury to yourself or others if you choose to install the wall mount on your own.

Wall Mount Kit Specifications (VESA)

Install your wall mount on a solid wall perpendicular to the floor. Before attaching the wall mount to building materials other than plaster board, please contact your nearest dealer for additional information. If you install the TV on a ceiling or slanted wall, it may fall and result in severe personal injury.

NOTE

- Standard dimensions for wall mount kits are shown in the table below.
- Samsung wall mount kits contain a detailed installation manual and all parts necessary for assembly.
- Do not use screws that do not comply with the VESA standard screw specifications.
- Do not use screws that are longer than the standard length or do not comply with the VESA standard screw specifications. Screws that are too long may cause damage to the inside of the TV set.
- For wall mounts that do not comply with the VESA standard screw specifications, the length of the screws may differ depending on the wall mount specifications.
- Do not fasten the screws too firmly. This may damage the product or cause the product to fall, leading to personal injury. Samsung is not liable for these kinds of accidents.
- Samsung is not liable for product damage or personal injury when a non-VESA or non-specified wall mount is used or the consumer fails to follow the product installation instructions.
- Do not mount the TV at more than a 15 degree tilt.
- Always have two people mount the TV on a wall.

Product Family	TV size in inches	VESA screw hole specs (A * B) in millimeters	Standard Screw	Quantity
LED-TV	19~22	75 X 75	M4	4
	27	200 X 100		
	32~40	200 X 200	M8	
	46~55	400 X 400		
	60~65	600 X 400		

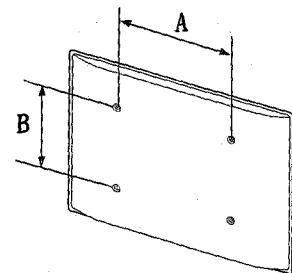

Do not install your Wall Mount Kit while your TV is turned on. It may result in personal injury due to electric shock.

Remote Control Buttons

This remote control has Braille points on the Power, Channel, and Volume buttons and can be used by visually impaired persons.

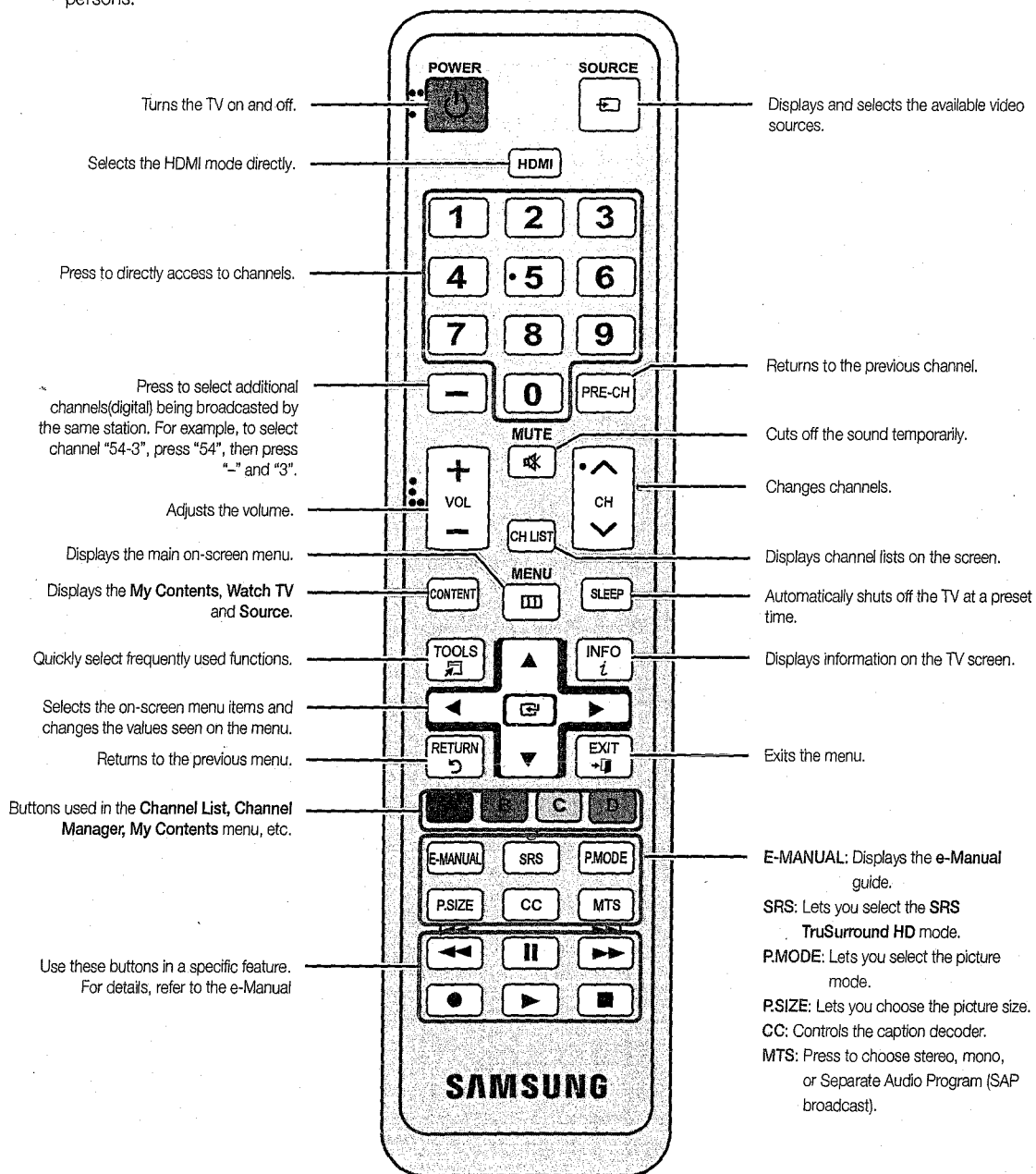

Installing batteries (Battery size: AAA)

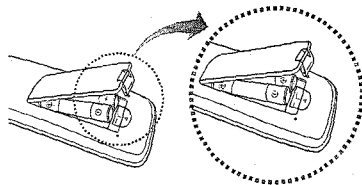

NOTE

- Use the remote control within 23-33 feet from the TV.
- Bright light may affect the performance of the remote control. Avoid using nearby special fluorescent light or neon signs.
- The color and shape may vary depending on the model.

How to Navigate Menus

Before using the TV, follow the steps below to learn how to navigate the menu and how to select and adjust different functions.

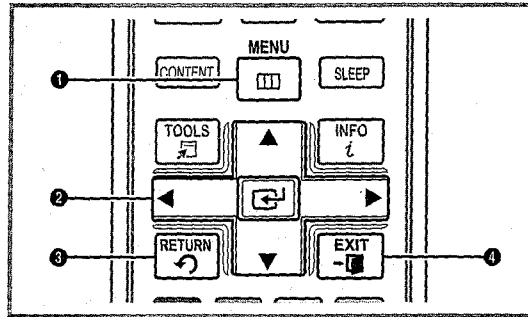

- 1 **MENU** button: Displays the main on-screen menu.
- 2 **ENTER** / Direction button: Move the cursor and select an item. Confirm the setting.
- 3 **RETURN** button: Returns to the previous menu.
- 4 **EXIT** button: Exits the on-screen menu.

How to Operate the OSD (On Screen Display)

The access step may differ depending on the selected menu.

- | | | |
|----------|--------------|--|
| 1 | MENU | The main menu options appear on the screen:
Picture, Sound, Channel, System, Support. |
| 2 | ▲ / ▼ | Select an icon or option with the ▲ or ▼ button. |
| 3 | ENTER | Press ENTER to access the sub-menu. |
| 4 | ▲ / ▼ | Select the desired submenu with the ▲ or ▼ button. |
| 5 | ◀ / ▶ | Adjust the value of an item with the ◀ or ▶ button. The adjustment in the OSD may differ depending on the selected menu. |
| 6 | ENTER | Press ENTER to confirm the selection. |
| 7 | EXIT | Press EXIT . |

For best cable connection to this product, be sure to use cables with a maximum thickness as below:

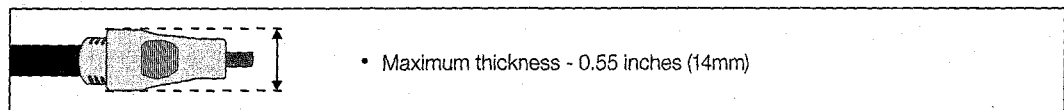

Connecting to an Antenna or Cable Connection

Connecting the power cord and an antenna or cable connection

When you move or swivel the TV with Antenna cable tightly connected, there is high risk antenna jack on TV will be broken off.

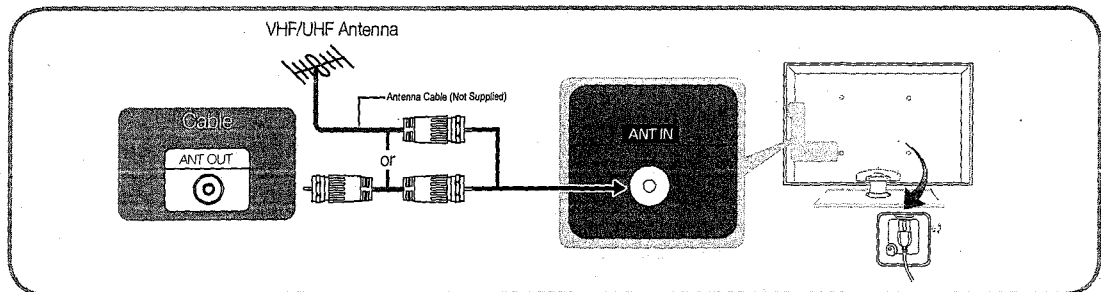

Plug & Play (Initial Setup)

When you turn the TV on for the first time, a sequence of on-screen prompts will assist in configuring basic settings. To turn on the TV, press the **POWER** button.

 **Plug & Play** is available only when the **Source** is set to TV.

 To return to the previous step in the **Plug & Play** sequence, press the red button on your remote.

1	Selecting the OSD Language	Press the ◀ or ▶ button, and then press the ▲ or ▼ button to select a language. Press ENTER when done.	
2	Selecting the usage mode	Press the ◀ or ▶ button to select, and then press the ENTER button. <ul style="list-style-type: none">Select the Home Use mode. Store Demo mode is for retail environments.	
3	Setting the Clock Mode	Press the ◀ or ▶ button. Press the ▲ or ▼ button to select Auto or Manual , and then press ENTER . <ul style="list-style-type: none">If you selected Auto, you'll select the time zone where you live next, and then select whether to turn DST (Daylight Savings Time) On or Off.If you selected Manual, you'll use the number buttons or ▲ or ▼ button to set the date and time. Use the ◀ or ▶ button to move between entry fields.	
4	Selecting search options for auto tuning	Press the ▲ or ▼ button to select Air or Cable , and then press ENTER . A check appears on your selection. Select Next , and then press the ENTER button. You can check both if you have both connected. <ul style="list-style-type: none">If you selected Cable, you'll go to the Cable System screen. Use the ▲ or ▼ button to select Digital or Analog, and then press ENTER. Use the ▲ or ▼ button to select the correct cable signal format - STD, HRC, or IRC - and then press ENTER. Most cable systems use STD. Select the correct cable signal format for both the Digital and Analog systems. When done, select Search, and then press ENTER.	
5	Selecting and memorizing channels	The channel search will start automatically. This can take up to 30 minutes. For more information, refer to Channel → Auto Program in the e-Manual . <ul style="list-style-type: none">Press the ENTER button at any time to interrupt the memorization process.	
6	Enjoy your TV.	Press the ENTER button.	

If You Want to Reset Plug & Play...

 **MENU** → **System** → **Plug & Play** → **ENTER**

 To change the TV's settings from **Store Demo** to **Home Use** when not in Plug & Play, press the volume button on the TV. When you see the volume in the OSD, press and hold **MENU** for 5 sec.

Connecting to an AV Device

Using an HDMI cable or HDMI to DVI Cable: HD connection (up to 1080p)

We recommend using the HDMI connection for the best quality HD picture.

Available devices: DVD, Blu-ray player, HD cable box, HD satellite receiver (STB)

HDMI IN 1 (DVI), 2, 3, 4 / PC/DVI AUDIO IN

- When using an HDMI/DVI cable connection, you must use the **HDMI IN 1 (DVI)** jack for video. A DVD, Blu-ray player, HD cable box, or HD STB satellite receiver may require a DVI-HDMI (DVI to HDMI) cable or DVI-HDMI (DVI to HDMI) adapter. The **PC/DVI AUDIO IN** jack is required for audio.
- Be sure to use an HDMI cable with a thickness of 14 mm or less.
- The picture may not display normally (if at all) or the audio may not work if an external device that uses an older version of HDMI mode is connected to the TV. If such a problem occurs, ask the manufacturer of the external device about the HDMI version and, if out of date, request an upgrade.
- Be sure to purchase a certified HDMI cable. Otherwise, the picture may not display or a connection error may occur.

Using a Component (up to 1080p) or Audio/Video (480i only) Cable

Available devices: DVD, Blu-ray player, cable box, STB satellite receiver, VCR

For better picture quality, the Component connection is recommended over the A/V connection.

Connecting to an Audio Device

Using an Optical (Digital) or Audio (Analog) Cable Connection

Available devices: Digital Audio System, Amplifier, Home Theater

DIGITAL AUDIO OUT (OPTICAL)

- When a Digital Audio System is connected to the **DIGITAL AUDIO OUT (OPTICAL)** jack, decrease the volume of both the TV and the system.
- 5.1 CH (channel) audio is available when the TV is connected to an external device supporting 5.1 CH.
- When the receiver (Home Theater) is set to on, you can hear sound output from the TV's optical jack. When the TV is receiving a DTV signal, the TV will send 5.1 CH sound to the Home Theater receiver. When the source is a digital component such as a DVD / Blu-ray player / cable box / STB (Set-Top-Box) satellite receiver and is connected to the TV via HDMI, only 2 CH audio will be heard from the Home Theater receiver. If you want to hear 5.1 CH audio, connect the digital audio out jack from your DVD / Blu-ray player / cable box / STB satellite receiver directly to an amplifier or Home Theater.

AUDIO OUT: Connects to the audio input jacks on your amplifier/Home Theater.

- When connecting, use the appropriate connector.
- When an audio amplifier is connected to the **AUDIO OUT** jacks: Decrease the volume of the TV and adjust the volume level with the amplifier's volume control.

Connecting to a PC

Using an HDMI cable or HDMI to DVI cable or a D-sub cable

Your PC may not support an HDMI connection.

Display Modes (D-Sub and HDMI/DVI Input)

Optimal resolution is 1360 x 768@60Hz. You can also select one of the standard resolutions listed in the Resolution column. The TV will automatically adjust to the resolution you choose.

Mode	Resolution	Horizontal Frequency (kHz)	Vertical Frequency (Hz)	Pixel Clock Frequency (MHz)	Sync Polarity (H/V)
IBM	640 x 350	31.469	70.086	25.175	+ / -
	720 x 400	31.469	70.087	28.322	- / +
MAC	640 x 480	35.000	66.667	30.240	- / -
	832 x 624	49.726	74.551	57.284	- / -
VESA DMT	640 x 480	31.469	59.940	25.175	- / -
		37.861	72.809	31.500	- / -
		37.500	75.000	31.500	- / -
	800 x 600	37.879	60.317	40.000	+ / +
		48.077	72.188	50.000	+ / +
		46.875	75.000	49.500	+ / +
	1024 x 768	48.363	60.004	65.000	- / -
		56.476	70.069	75.000	- / -
		60.023	75.029	78.750	+ / +
		47.712	60.015	85.500	+ / +

NOTE

- For HDMI/DVI cable connection, you must use the **HDMI IN 1 (DVI)** jack.
- The interlace mode is not supported.
- The set might operate abnormally if you select a non-standard video format.
- Separate and Composite modes are supported. SOG (Sync On Green) is not supported.

EX-LINK

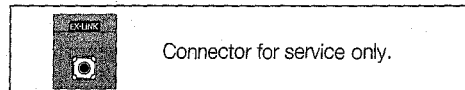

Changing the Input Source

Source

Use to select TV or an external input sources such as a DVD / Blu-ray player / cable box / STB satellite receiver.

1. Press the **SOURCE** button.
2. Select a desired external input source.

- **TV / Component / PC / HDMI1 / DVI / HDMI2 / HDMI3 / HDMI4 / AV / USB**



- You can only choose external devices that are connected to the TV. In the **Source**, connected inputs will be highlighted.
- If you want to see connected devices only, move to **Connected** using ◀ or ▶ button.
- **PC** always stay activated.
- If the connected external devices are not highlighted, press the red button. The TV will search for connected devices.

How to use Edit Name

Edit Name lets you associate a device name to an input source. To access **Edit Name**, press the **TOOLS** button in **Source**. The following selections appear under **Edit Name**:

- **VCR / DVD / Cable STB / Satellite STB / PVR STB / AV Receiver / Game / Camcorder / PC / DVI PC / DVI Devices / TV / IPTV / Blu-ray / HD DVD / DMA**: Name the device connected to the input jacks to make your input source selection easier.

• If you have connected a PC to the **HDMI IN 1 (DVI)** port with an HDMI cable, select **PC** under **Edit Name** to enter a device name.

• If you have connected a PC to the **HDMI IN 1 (DVI)** port with an HDMI to DVI cable, select **DVI PC** under **Edit Name** to enter a device name.

• If you connected an AV device to the **HDMI IN 1 (DVI)** port with an HDMI to DVI cable, select **DVI Devices** under mode under **Edit Name** to enter a device name.

Information

You can see detailed information about the selected external device.

How to view the e-Manual



You can find instructions for your TV's features in the **e-Manual** in your TV. To use, press the **E-MANUAL** button on your remote. Move the cursor using the up/down/right/left buttons to highlight a category, then a topic, and then press the **ENTER** button. The **e-Manual** displays the page you want to see.

You can also access it through the menu:

MENU → **Support** → **e-Manual** → **ENTER**

To return to the **e-Manual** main menu, press the **E-MANUAL** button on the remote.

You cannot use **Try Now** directly if the TV is set to an external input source.

Screen Display

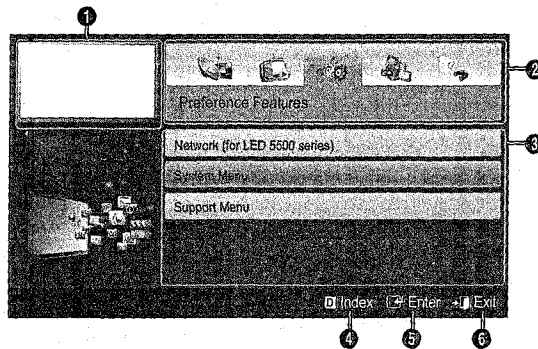

- 1 Currently displayed video, TV program, etc.
- 2 The category list. Press ◀ or ▶ button to select the category you want.
- 3 Displays the sub-menu list. Use the arrow buttons on your remote to move the cursor. Press the **ENTER** button to select the sub-menu you want.
- 4 **Blue (Index)**: Displays the index screen.
- 5 **Enter**: Selects a category or sub-menu.
- 6 **Exit**: Exit the e-Manual.

How to toggle between an e-Manual topic and the corresponding OSD menu(s).

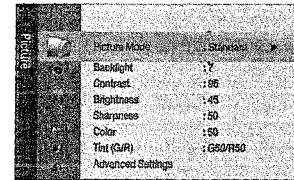
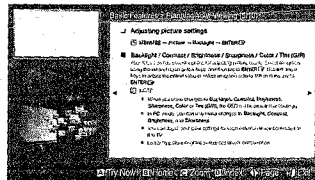

This function is not enabled in some menus.

Method 1

1. If you want to use the menu that corresponds to an **e-Manual** topic, press the red button to select **Try Now**.
2. To return to the **e-Manual** screen, press the **E-MANUAL** button.

Method 2

1. Press the **ENTER** button when a topic is displayed. "Do you want to execute this?" appears. Select **Yes**, and then press the **ENTER** button. The OSD window appears.
2. To return to the **e-Manual** screen, press the **E-MANUAL** button.

Viewing the Contents

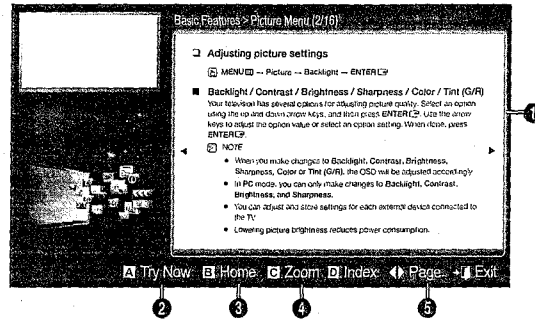

- 1 Contents Area: Contains the topic contents, if you selected a sub-menu. To move to the previous or next page, press the ◀ / ▶ button.
- 2 Try Now: Displays the OSD menu that corresponds to the topic. To return to the e-Manual screen, press the E-MANUAL button.
- 3 Home: Moves to the e-Manual home screen.
- 4 Zoom: Magnifies a screen. You can scroll through the magnified screen by using ▲ / ▼ buttons.
- 5 ◀▶ (Page): Moves to previous or next page.

Using the Zoom mode

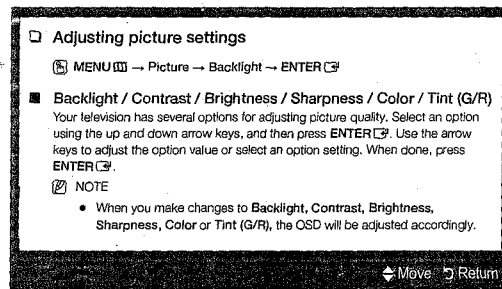

Press the  (yellow) button to magnify the contents area. You can scroll through the magnified screen by using the ▲ or ▼ buttons.

 To return to the screen to normal size, press the RETURN button.

How to search for a topic on the index page

1. To search for a topic, press the left or right arrow button to select a letter, and then press ENTER. The Index displays a list of topics and keywords that begin with the letter you selected.
 2. Press the up or down arrow button to select a topic or keyword, and then press the ENTER button.
 3. The e-Manual page with the topic appears.
-  To close the Index screen, press the RETURN button.

Troubleshooting

If the TV seems to have a problem, first review this list of possible problems and solution. Also review the Troubleshooting Section in the e-Manual. If none of the troubleshooting tips apply, visit www.samsung.com/support or call Samsung customer Service at 1-800-SAMSUNG(1-800-726-7864).

Issues	Solutions and Explanations
Flickering and Dimming	<p>If your Samsung Television is flickering or dimming sporadically, you may need to disable some of its energy efficient features like the Energy Saving feature. If you follow below step with your remote, you can turn these features off or on.</p> <ul style="list-style-type: none"> • Energy saving: User Menu → System → Eco Solution → Energy Saving
Component Connections / Screen Color	<p>If you find that the color on your Samsung television's screen is not correct or black and White, first run a Self Diagnosis on the TV to make sure there are no device issues.</p> <ul style="list-style-type: none"> • Self Diagnosis : User Menu → Support → Self Diagnosis → Picture Test <p>If the test is ok, try making sure ;</p> <ul style="list-style-type: none"> • Your connections are all consistent. For example, if you've used the AV In jack on your TV, make sure you have used the AV Out jack on your video source. • Try making sure you have connected to the correct jacks. For example, if you use the Component jacks, labeled Pb, Pr, and Y, to connect your TV and video source, make sure you have connected the blue Pb jack on the video source to the blue Pb jack on the TV, the red Pr jack on the source to the red Pr jack on the TV.
Screen Brightness	<p>If you find that the colors on your Samsung TV are correct but just a little too dark or bright, there are some settings you should check before calling for a repair.</p> <ul style="list-style-type: none"> • Backlight, Contrast, Brightness, Sharpness, Color, Tint and so on. <p>Go in to "Picture" on user Menu then try adjusting options mentioned above.</p>
Unwanted Powering off	<p>If your Samsung TV appears to turn off by itself, there may be an issue with either your Timer settings or your Eco friendly No Signal Power Off feature.</p> <p>First make sure you Sleep Timer is not accidentally set. The sleep timer allows you the comfort of falling asleep with the TV still on but, turns it off after a certain period of time so as not to waste energy.</p> <ul style="list-style-type: none"> • Sleep Timer : User Menu → System → Time → Sleep Timer <p>If the Sleep Timer is not activated, you may have engaged the No Signal Power Off or Auto Power Off feature.</p> <ul style="list-style-type: none"> • No Signal Power Off : User Menu → System → Eco Solution → No Signal Power Off • Auto Power Off : User Menu → System → Eco Solution → Auto Power Off
Trouble Powering On	<p>Before Turn on check red light on the right or left bottom of your TV. Press power on button on TV or remote and it will blink about 5 times before turning on.</p> <p>If you find that you are having trouble powering on your Samsung television, there are a number of things to check before making a call to the service department.</p> <ul style="list-style-type: none"> • If you happen to be using the TV as a monitor and the stand-by light only blinks for a few seconds when you press the power button, your PC is in sleep mode. To take your PC out of sleep mode, press a key on your keyboard or move the mouse. Then try turning your TV on. <p>If you're sure your power cord, remote control, and PC are functioning properly, you may be having a cable issue. If you have a cable or satellite box, your TV may appear to be off because the cable or satellite box is not outputting a signal. To test the signal output of your cable or satellite box, press the guide or info button on the cable or satellite box remote control. If the screen displays the guide or info data, the problem is caused by the box.</p>
Stand Assembly	<p>If you have any trouble to assemble the stand though you refer to "Install the Stand" mentioned at this manual, visit www.samsung.com/spsn then check "2011 Stand Assembly" on "Top 7 TV Troubleshooting Tips".</p>
Cannot find channel	<p>Re-run plug and play. See page 9 for detail</p>

 Watch these troubleshooting on video at www.samsung.com/spsn

Troubleshooting

If the TV seems to have a problem, first review this list of possible problems and solutions. Also review the Troubleshooting section in the e-Manual. If none of the troubleshooting tips apply, visit samsung.com, and then click on Support, or call Samsung customer service at 1-800-SAMSUNG.

Issues	Solutions and Explanations
The TV will not turn on.	<ul style="list-style-type: none"> • Make sure the AC power cord is securely plugged into the wall outlet and the TV. • Make sure the wall outlet is working. • Try pressing the POWER button on the TV to make sure the problem is not the remote. If the TV turns on, refer to 'Remote control does not work' below.
The TV turns off automatically.	<ul style="list-style-type: none"> • Ensure the Sleep Timer is set to Off in the System menu. • If your PC is connected to the TV, check your PC power settings. • Make sure the AC power cord is plugged in securely to the wall outlet and the TV. • When you are watching TV connected to an antenna or cable connection, the TV will turn off after 10 - 15 minutes if there is no signal.
There is no picture/video	<ul style="list-style-type: none"> • Check the cable connections. Remove and reconnect all cables connected to the TV and external devices. • Set the video outputs of your external devices (Cable/Set top Box, DVD, Blu-ray etc) to match the TV input connections. For example, if an external device's output is HDMI, it should be connected to an HDMI input on the TV. • Make sure your connected devices are powered on. • Be sure to select the TV's correct input source by pressing the SOURCE button on the remote control. • Reboot the connected device by unplugging and then reconnecting the device's power cable.
The remote control does not work.	<ul style="list-style-type: none"> • Replace the remote control batteries. Make sure the batteries are installed with their correct polarities (+/-) in the correct direction. • Clean the transmission window located on the top of the remote. • Try pointing the remote directly at the TV from 5-6 feet away.
The cable/set top box remote control does not turn the TV on or off, or adjust the volume.	<ul style="list-style-type: none"> • Program the Cable/Set top Box remote control to operate the TV. Refer to the Cable/Set top Box user manual for the SAMSUNG TV code.

 This TFT LED panel uses a panel consisting of sub pixels which require sophisticated technology to produce. However, there may be a few bright or dark pixels on the screen. These pixels will have no impact on the performance of the product.

 You can keep your TV as optimum condition to upgrade the latest firmware on web site (samsung.com → Support → Downloads) by USB.

License



List of Features

Excellent Digital Interface: With a built-in HD digital tuner, nonsubscription HD broadcasts can be viewed without a cable box / STB (Set-Top-Box) satellite receiver.

- **My Contents**
Allows you to play music files, pictures, and movies saved on a USB device.
- **Anynet+(HDMI-CEC)**
Allows you to control all connected Samsung devices that support anynet+ with your Samsung TV's remote.

Securing the TV to the Wall



Caution: Pulling, pushing, or climbing on the TV may cause the TV to fall. In particular, ensure your children do not hang over or destabilize the TV. Doing so may cause the TV to tip over, causing serious injuries or death. Follow all safety precautions provided in the Safety Flyer included with your TV. For added stability and safety, you can purchase and install the anti-fall device as described below.

The TV-Holder Kit (Sold Separately)

The parts below are included in the TV Holder kit. In addition, you need to provide a wood screw, screw and molly, or other screw appropriate for the wall or cabinet you intend to secure the TV-Holder string to. We recommend a size M4xL20 wood screw.



TV-Holder (BN06-15753A)

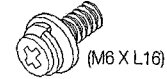

Screw (M6 X L16)

Installing the TV-Holder

1. Remove the screw attached to the back of your TV, and then connect the TV-Holder to the TV with the screw included in the TV Holder Kit that is designated for your TV.
 - ✎ Make sure to use only the appropriate supplied screw. If you use a different screw, you can damage your TV.

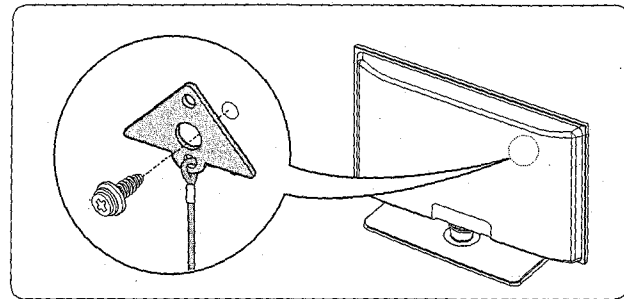

2. Firmly fasten the screw you provided (size M4xL20 or similar) to the wall or cabinet where the TV is to be installed.
 - ✎ If you fasten the screw to the wall, we recommend you drive the screw into a stud. If that is not possible, use a molly to anchor the screw.
3. Tie the TV-Holder cord to the screw fastened to the wall or cabinet so that the TV is fixed. See the illustrations below.
 - ✎ Install the TV close to the wall so that it does not fall.
 - ✎ When attaching the TV Holder cord to the wall, tie the cord level with the ground or slanted downwards for safety purposes.
 - ✎ Check the cord occasionally to make sure it is secure.
 - ✎ Before moving the TV, separate the connected cord first.

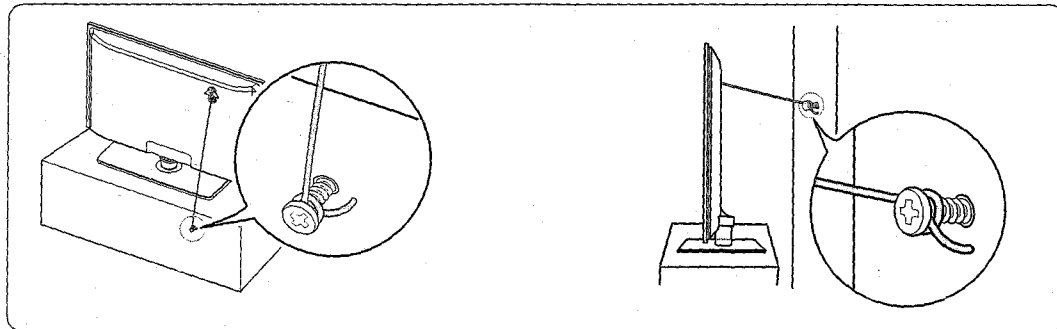

4. Verify all connections are properly secured. Periodically check the connections for any sign of fatigue or failure. If you have any doubt about the security of your connections, contact a professional installer.

To purchase the TV-Holder Kit, contact Samsung Customer Care

- In the United States: 1-800-Samsung (1-800-726-7864)
- In Canada: 1-800-Samsung (1-800-726-7864)

Storage and Maintenance

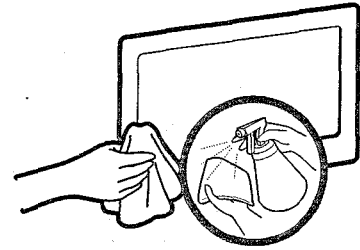
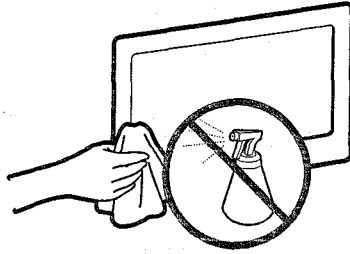



Do not spray water or a cleaning agent directly onto the product. Any liquid that goes into the product may cause a failure, fire, or electric shock.

Clean the product with a soft cloth dampened with a small amount of water.

Specifications

Display Resolution	1360 x 768
Environmental Considerations	
Operating Temperature	50°F to 104°F (10°C to 40°C)
Operating Humidity	10% to 80%, non-condensing
Storage Temperature	-4°F to 113°F (-20°C to 45°C)
Storage Humidity	5% to 95%, non-condensing
Model Name	UN32D4000ND / UN32D4010ND
Screen Size (Diagonal)	32" Class (31.5" measured diagonally)
Sound (Output)	10W X 2
Dimensions (WxDxH)	
Body	30.1 X 1.2 X 18.2 inches (763.6 X 29.9 X 463.1 mm)
With stand	30.1 X 8.8 X 20.8 inches (763.6 X 222.7 X 527.1 mm)
Weight	
Without Stand	15.4 lbs (7.0kg)
With Stand	19.8 lbs (9.0kg)

-  Design and specifications are subject to change without prior notice.
-  This device is a Class B digital apparatus.
-  For information about power supply, and more about power consumption, refer to the label attached to the product.

Dispose unwanted electronics through an approved recycler.
To find the nearest recycling location, go to our website:
www.samsung.com/recyclingdirect or call, (877) 278 - 0799

Dimensions

■ Front view / Side view

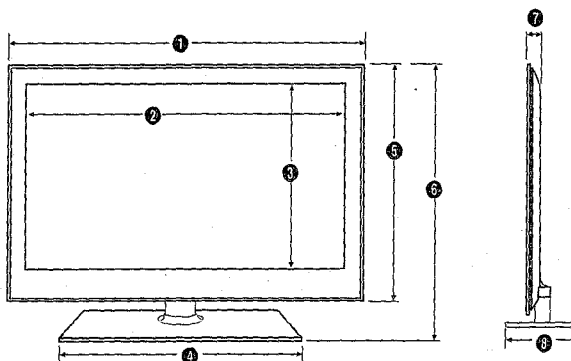

(Unit: inches)

Model name	1	2	3	4	5	6	7	8
UN32D4000ND	30.1	27.5	15.5	17.8	18.2	20.8	1.2	8.8
UN32D4010ND								

■ Jack panel detail / Rear view

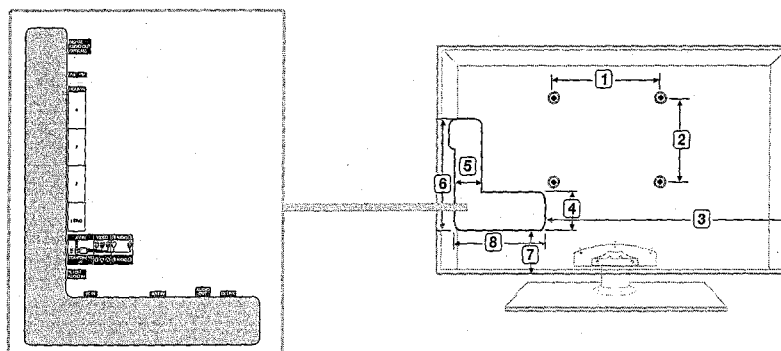

(Unit: inches)

Model name	1	2	3	4	5	6	7	8
UN32D4000ND	7.8	7.8	19.7	2.5	0.7	9.6	5.8	6.8
UN32D4010ND								

NOTE: All drawings are not necessarily to scale. Some dimensions are subject to change without prior notice. Refer to the dimensions prior to performing installation of your TV. Not responsible for typographical or printed errors.

© 2011 Samsung Electronics America, Inc



Contact SAMSUNG WORLDWIDE

If you have any questions or comments relating to Samsung products, please contact the SAMSUNG customer care center.

Country	Customer Care Center ☎	Web Site	Address
CANADA	1-800-SAMSUNG (726-7864)	www.samsung.com	Samsung Electronics Canada Inc., Customer Service 55 Standish Court Mississauga, Ontario L5R 4B2 Canada
U.S.A	1-800-SAMSUNG (726-7864)	www.samsung.com	Samsung Electronics America, Inc. 85 Challenger Road Ridgefield Park, NJ 07660

